

### MOUNTING

The SMD range of side mounted dipole antennas offer system designers a wide choice in the areas of horizontal radiation patterns and gain. The following radiation patterns were measured when an SMD1 was mounted with the stated antenna to mast spacings. The pattern changes dramatically with this spacing on other than a 50mm diameter mast. In the case of a larger mast (eg: lattice mast structure), the overall effect is thinner main lobes and more pronounced nulls.

### PHASING

When phasing SMD antennas, designers should first take into account the antenna to mast spacings. The effect in the H plane of phasing SMD antennas is fairly minimal, with only a slight reduction in the horizontal beamwidths (as shown for a single antenna) when up to four antennas are phased. Gain is increased nominally by 3dB when a second antenna is used and 6db for an array of four.

Vertical radiation patterns are generally larger than for a series fed colinear (ie fibreglass enclosed) due to the directional nature of the array - one of the obvious advantages of using an SMD antenna. SMD antennas also offer beamtilt stability over a fairly broad bandwidth (up to +/- 10%) and direct grounding for lightning protection. The chart below indicates the optimum spacings between antennas when phasing. Our range of phasing harnesses is listed on page 74.

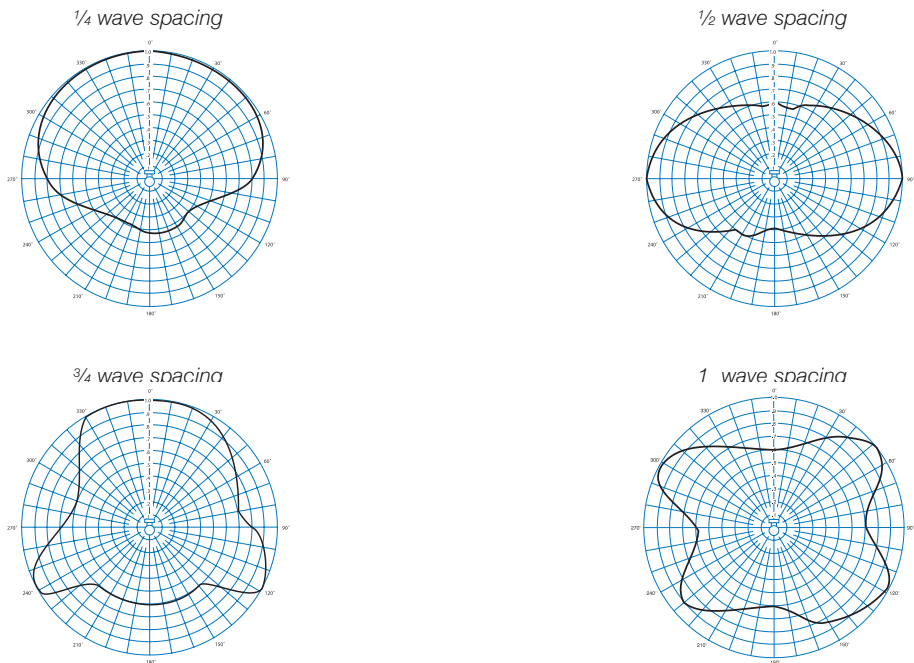

Model Number	MHz Centre frequency	D= 1/4 wave	D= 1/2 wave	D= 3/4 wave	D= 1 wave	S
SMD1	77	974	1948	2922	3896	2922
SMD2	161	466	932	1398	1863	1398
SMD4	460	163	326	489	652	489

### Phasing UHF Dipole Antennas

When using side mounted dipole antennas it is important to ensure that the antenna to mast spacings AND the antenna to antenna spacings are optimised for your application. The following graphs indicate the optimum antenna centre to antenna centre spacings and antenna to mast spacings for your frequency of use.

On the previous page is an illustration of the various patterns effected at VHF frequencies when side mounted dipole antennas are mounted at differing distances from the support mast.

A similar series of patterns will also be effected at UHF frequencies, however it is important to note that for any given support mast, the effect on a UHF antenna will be greatly exaggerated, with deeper nulls and more pronounced peaks in the pattern. We urge the use of our BA, EA and OA Series arrays at UHF for predictable pattern performance.

Please note that when using two side mounted dipole antennas phased together, total antenna gain will be increased by 3 dB and if using four antennas, the antenna gain will be increased by 6 dB. This increase in gain is IN ADDITION to any gain which is afforded by the manipulation of the antenna pattern through antenna to mast spacings as shown opposite.

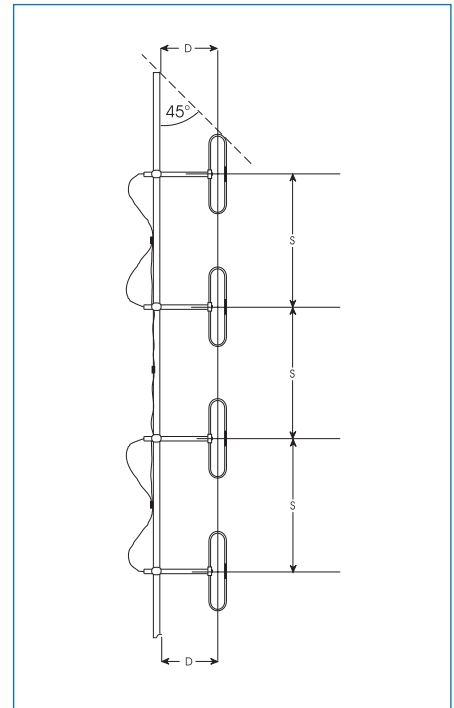

Four stack

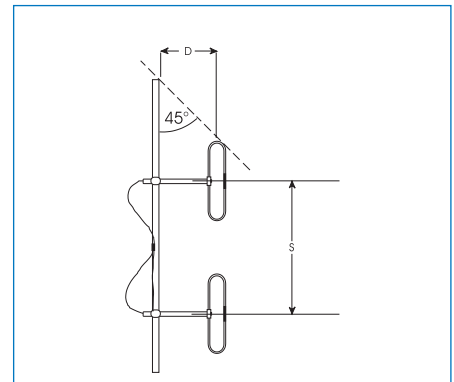

Two stack

**PLEASE NOTE:** We strongly recommend against the phasing of 800 MHz side mounted dipole antennas as the control of the dimensions is far too critical to be adequately controlled in the field. Thus, we do not publish any information to assist in the phasing of our 800 MHz side mount dipole antennas.

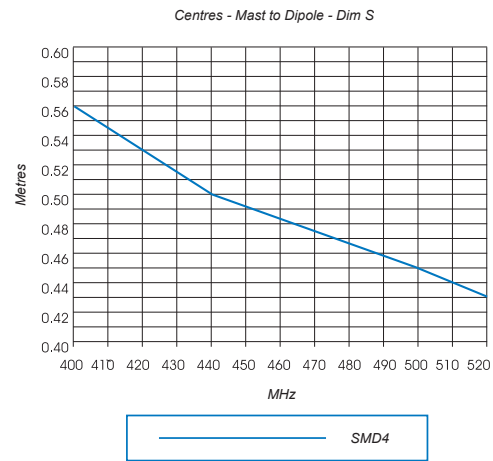
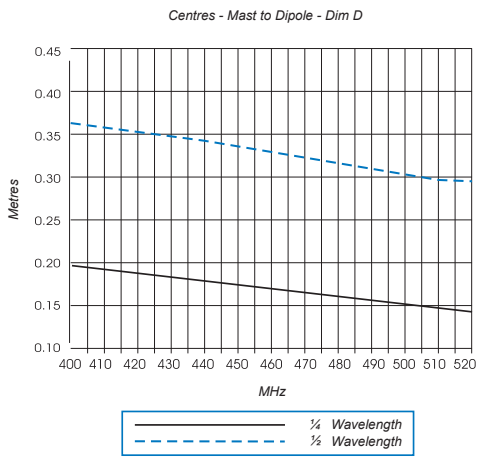

### Dipole Spacing vs Frequency

### Phasing VHF Dipole Antennas

When using side mounted dipole antennas it is important to ensure that the antenna to mast spacings AND the antenna to antenna spacings are optimised for your application. The following graphs indicate the optimum vertical spacings and antenna to mast spacings for your frequency of use.

Earlier in this section is an illustration of the various patterns effected at VHF frequencies when side mounted dipole antennas are mounted at differing distances from the support mast.

Please note that when using two side mounted dipole antennas phased together, total antenna gain will be increased by 3 dB and if using four antennas,

the antenna gain will be increased by 6dB.

This increase in gains is IN ADDITION to any gain which is afforded by the manipulation of the antenna pattern through antenna to mast spacings as shown opposite.

**PLEASE NOTE:** For both SMD1 and SMD2 antennas, the full band coverage of the antennas can be maintained for a stack of two or four antennas if the correct phasing harness is used.

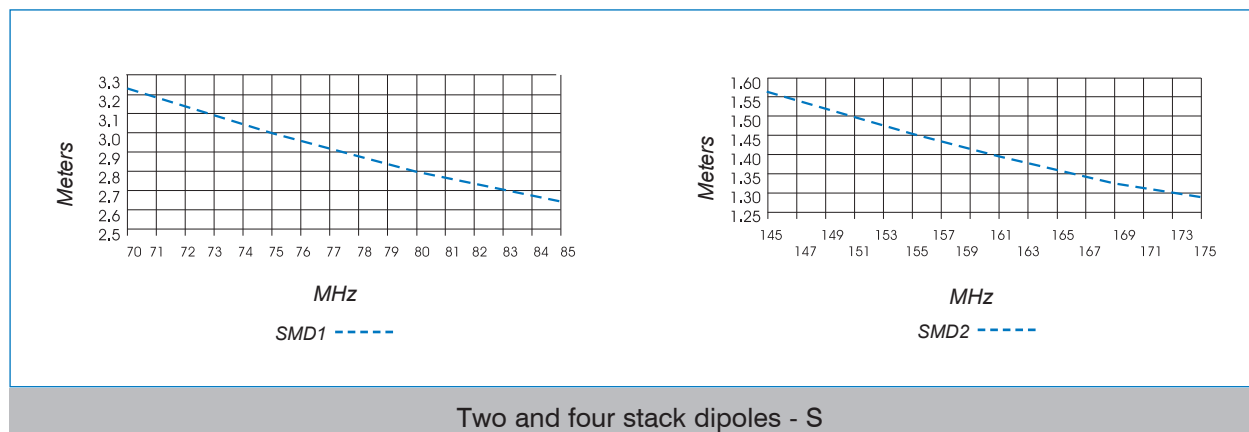
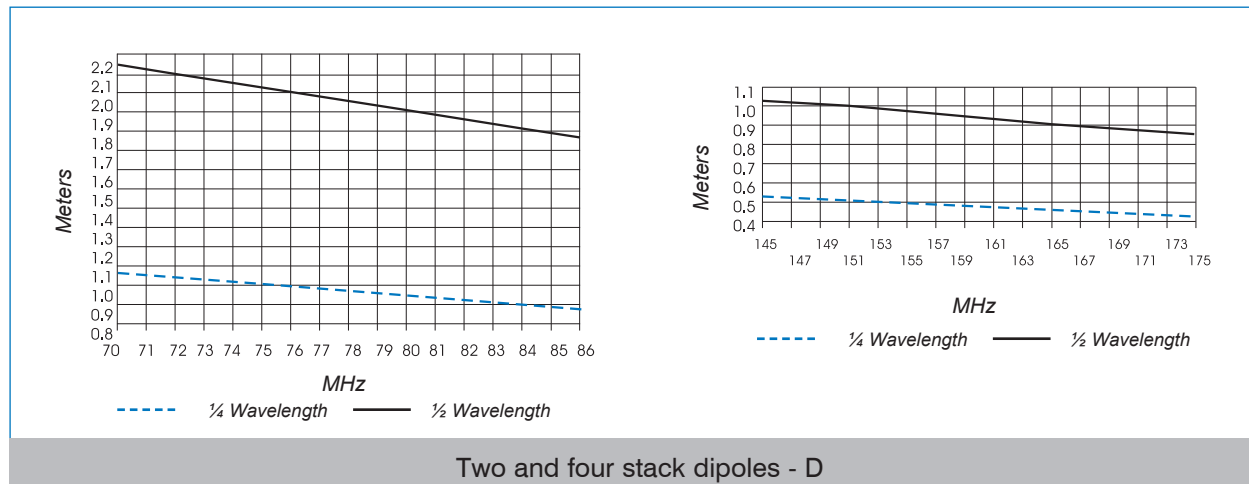

The phasing of yagi antennas can be done in vertical or horizontal polarisation and will, when properly implemented, boost the available gain by 3.0 dB (for two antennas) or 6.0 dB (for four antennas) over the gain for a single antenna.

The phasing of yagi antennas requires critical control of both the “Baying” and “Stacking” dimensions as shown in the illustrations. It is important to note that in all cases, these dimensions (B and S from our illustrations) should be identical at any one frequency.

These distances vary with the number of antenna elements and the frequency of operation. To ensure that your antennas are phased at the optimum distance, use the following charts to determine the distance which should be used for the antennas you are using.

**PLEASE NOTE:** If you are phasing antennas in MULTIPLE directions, rather than phasing yagi antennas together for additional gain in a single direction, you will experience a net LOSS in gain over your individual antenna gain of 3.0 dB for a two way split and 6.0 dB for a four way split.

For more information on the effect of phasing yagi antennas, please contact your nearest RFI office.

